



PIPE COUPLINGS

HAMMER UNION - FIGURE 602
& FIGURE 602 BUTT WELD

6,000 PSI CWP - 9,000 PSI TEST

FEATURES & APPLICATIONS:

- Compact design is well-suited for manifold service. Employs a double seal that combines an elastomeric gasket with a metal-to-metal connection.
- Figure 602 is specifically designed to minimize fluid flow turbulence. The BUNA-N replaceable lip-type seal ring that provides this capability also provides a pressure seal and protection for the metal-to-metal seated surfaces. These unions are recommended for manifold and truck mounting where size and weight are critical, as well as air, water, oil, gas or mud service where working pressures do not exceed 6,000 PSI NSCWP.

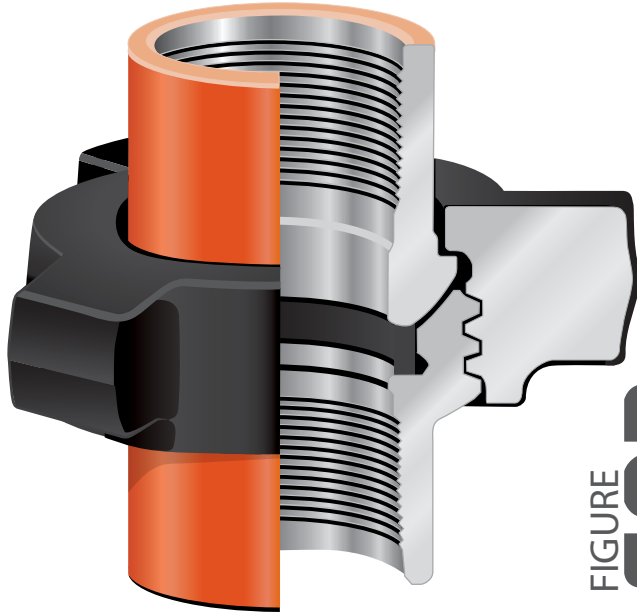

FIGURE
602

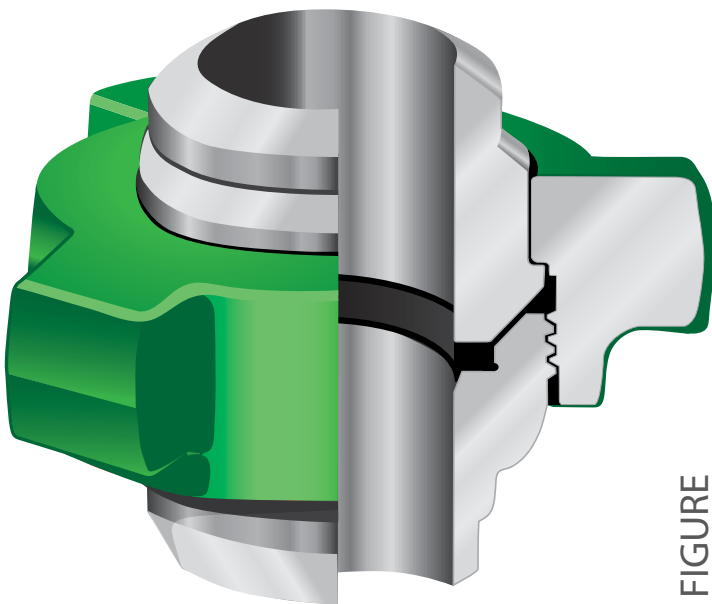

FIGURE
602

TECHNICAL DATA:

- Sizes: 1" - 4"
- Pressure Rating: 6,000 PSI NSCWP
- End Connections: Threaded & Butt-Weld
- Butt-Weld Schedules: 80 (XH)
- BUNA-N lip-type seal ring (-20°F to 250°F)
- Color Code: Orange Subs / Black Nut

6000 PSI CWP		
SIZE	FIGURE 602	BUTT WELD FIGURE 602
1"	HU602-100T	---
1 1/2"	HU602-150T	---
2"	HU602-200T	HU602-200BW
3"	HU602-300T	HU602-300BW
4"	HU602-400T	HU602-400BW



PIPE COUPLINGS
HAMMER UNION - FIGURE 602

6,000 PSI CWP - 9,000 PSI TEST

Compact design is well-suited for manifold service. Employs a double seal that combines an elastomeric gasket with a metal-to-metal connection.

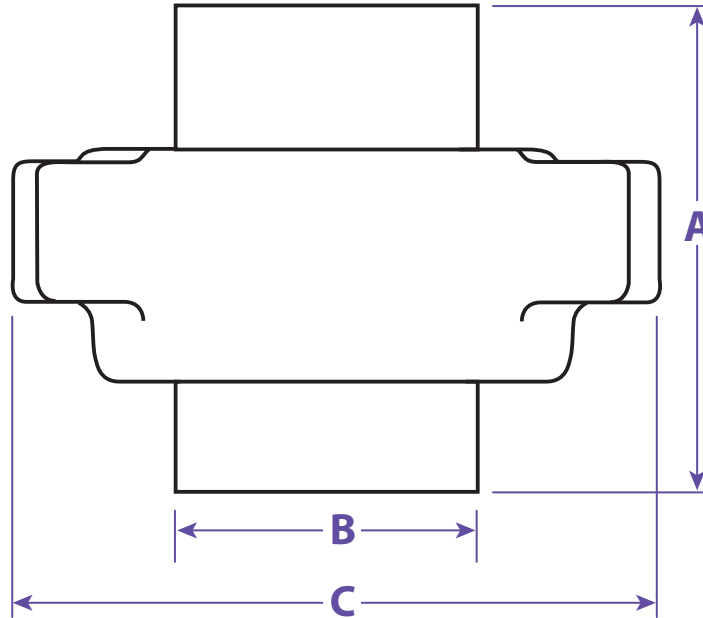

Size / Weight									
IN	MM	Lbs	A	B	C	ACME TPI	MATERIAL NUTS	SUBS	Part #
1"	25	3.55	6.625	1.750	4.500	6 STD	SF	SF	HU602-100T
1 1/2"	40	9.54	4.600	2.570	5.520	4 STD	SF	SF	HU602-150T
2"	50	12.25	5.300	2.970	6.875	3 MOD	SF	SF	HU602-200T ..BW
3"	80	22.30	6.310	4.250	8.875	3 MOD	SF	SF	HU602-300T ..BW
4"	100	32.18	8.300	5.200	10.040	3 MOD	SF	SF	HU602-400T ..BW

Fig. No.	Standard Service		Pipe Size(in)										End Connection
	CWP	Test	1	1 1/4	1 1/2	2	2 1/2	3	4	6	8		
602	6,000	9,000	✓		✓	✓		✓	✓				T / BW

TITLE PIPE COUPLINGS - HAMMER UNION FIGURE 602

DISCLAIMER
All drawings and specifications are subject to change without notice. Drawings represent general dimensions of our products. Seal Fast cannot guarantee the dimensions of the part will exactly match those in the drawing. This drawing is the property of Seal Fast Inc. Copying or reproduction of this drawing is expressly prohibited.

MATERIAL
SF

DRAWING NOT TO SCALE

PART # HU602-xxxT, BW

